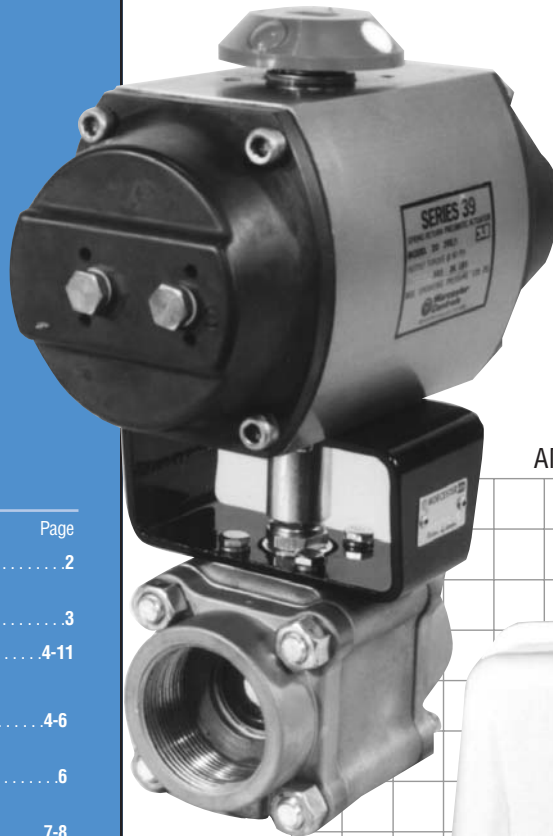

Table of Contents

	Page
Definition of Valve Torque	2
Determination of Valve Torque Actuator Selection	3
Pressure Torque Curves	4-11
Standard Reduced Port Valves and Series 94 Valves (with TFE [®] Stem Seals)	4-6
Series H71 High Pressure Ball Valves	6
Series 94, AF94 and FZ94 Valves (with Grafoil [®] Stem Seals)	7-8
Chlorine Ball Valves	9
Polyfill [®] Seats - Cryogenic Service only Series T44 Three-way Valves	9
One-piece Seats and Seals	9
10" Series 51/52 Reduced Port Valves	10
8" and 10" Series 82/83 and 8" Series 818/828 Full Port Valves	10
Series WK70 Tube Bore Clean Valves	10
Characterized Seat Control Valves	11
Actuator Output Charts	12-13
Series 34 Pneumatic Actuator Series 36 Electric Actuator Series 39 Pneumatic Actuator Series 75 Electric Actuator	
Examples	14-15



AN ISO 9001 REGISTERED COMPANY



Actuator Sizing Manual

For Worcester Controls Valves

Definition of Valve Torque

The purpose of this manual is to provide a simple yet accurate procedure for sizing actuators to Worcester ball valves. By properly sizing an actuator to a valve for a specific application, performance is guaranteed and economies are gained.

VALVE TORQUE - Before the actuator can be sized for any given valve application, the amount of torque required by the valve must be determined. The operating torque of the ball valve is influenced by a number of factors, some are design and material related, others are application (service condition) related. Design related factors include the type and material of the valve seats. Application factors include system pressure, media, and frequency of operation.

The torque required to operate a ball valve comes from two different areas within the valve, in both cases resulting from friction between metal and relatively soft sealing materials. The two areas in the valve that create torque are the stem and ball/seat.

Stem torque is primarily dependent upon the tightness of the stem nut. Proper adjustment of the stem nut is important to valve performance and life. If the nut is too loose, the valve exhibits stem leakage; if the nut is too tight, the total torque requirement can be increased to the point where the actuator may not be powerful enough to cycle the valve. The design of Worcester ball valves is such that the stem torque is constant, i.e., it is not influenced by operating conditions.

Ball/seat torque is created by the friction between the ball and seat, and is very sensitive to service conditions. The “floating ball” design concept allows the system pressure to force the ball into the downstream seat. The higher the system pressure, the harder the ball is forced into the seat, and, therefore, the higher the torque. Since different seat materials have different coefficients of friction, the ball/seat torque also becomes a function of the seat materials being used.

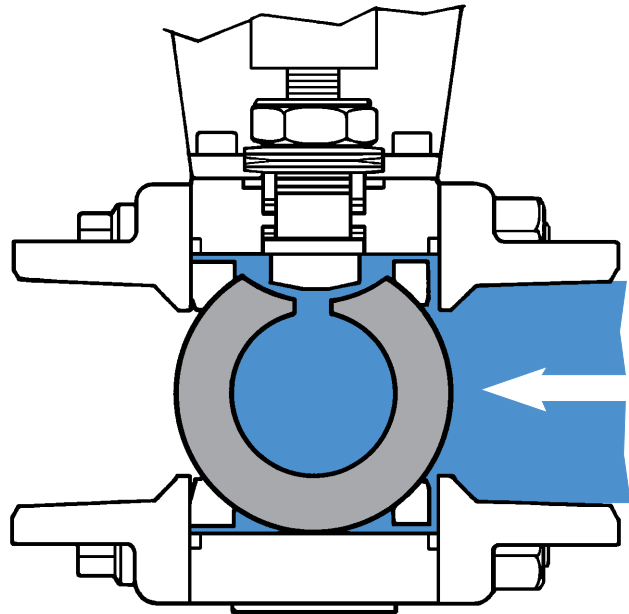

Valve shown in closed position, full pressure.

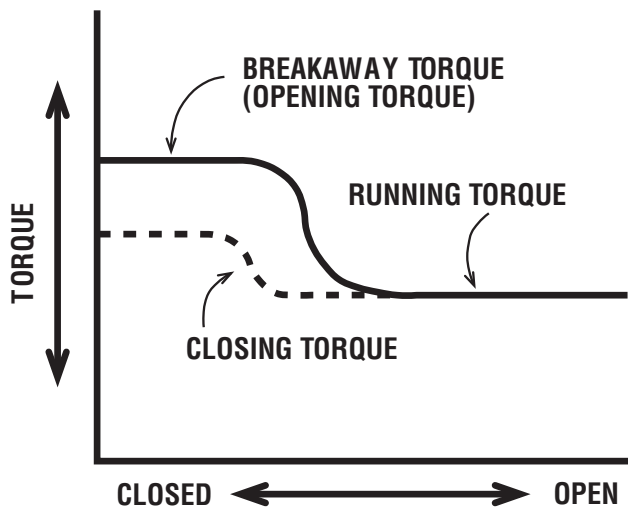

Valve torque is also a function of the media flowing through the valves. Abrasive media have a tendency to increase the amount of friction between ball and seats, whereas some light oils, which provide additional lubricity, can reduce the amount of torque required.

The torque required to operate a ball valve is maximum at the beginning of opening. This is due to change in the ball surface that is in contact with seats. The ball surface contact with the seats is greatest when the valve is closed.

A typical ball valve torque characteristic is demonstrated in the graph shown on the left. Closing torque is about 80% of the opening or breakaway torque for the softer resilient seats such as TFE and Buna N. For harder seats such as Lubetal, High-per Fill®, Metal A and Metal G, the opening and closing curves are nearly identical. Torque curves in this publication are based on opening curves.

All pressure-torque curves contained herein are the result of laboratory testing using water at ambient temperature as the medium. Torque values derived from these curves, when the appropriate service condition corrections factors are applied, will be adequate for the vast majority of applications. Consult the factory for valves using other seat materials or when severe service conditions exist.

Determination of Valve Torque

Standard Reduced Port Ball Valves

The valve torque curves (pages 4-11) show the torque requirements of ¼" through 10" Worcester ball valves as a function of differential pressure across the valve when the ball is in the closed position.

NOTE: These curves have been developed for applications involving CLEAN media.

Based on valve size, seat material and differential pressure across the valve (in the closed position), the amount of torque required by the ball valve can be determined by the following procedures:

1. Find the valve torque from the torque curves on pages 4-11 by using the differential pressure across the valve in the closed position. To do this, locate the differential pressure on the horizontal axis of the chart and move up until you arrive at the appropriate valve size, transfer the intersecting point across to the vertical axis of the graph, and read the required torque.
2. Multiply this torque value by one or more of the application factor multipliers shown below. Maximum cumulative multiplier = 2.

APPLICATION FACTOR	MULTIPLIER
A. Service	
On-off.....	1.0
Emergency shutdown cycled less than once per month.....	2.0
Throttling control w/positioner	1.2
Applications with less than 2 cycles/day.....	1.2
Applications below -20°F.....	1.25
B. Media	
Saturated steam.....	1.2
Clean saturated steam	1.0
Liquid, clean (particle free).....	1.0
Liquid, dirty (slurry), raw water	1.8
Gas, clean and wet.....	1.2
Gas, clean and dry (super heated steam)	1.0
Gas, dirty (natural gas).....	1.5
Chlorine	1.5

Full Ported Ball Valves

When determining torque requirements for full ported ball valves, (series 59, 818/828, 82/83) refer to the following table to identify which standard ported valve torque will be equal to the full ported size, then follow steps 1 and 2.

Full Port	Standard Reduced Port
¼", ⅜"	½"
½"	¾"
¾"	1"
1"	1¼"
1¼"	1½"
1½"	2"
2"	2½"
3"	4"
4"	6"
6"	8"
8"	10"

Series 94 Valves

Series 94 valves with TFE, reinforced TFE, Polyfill and Metal A seats with TFE stem seals use the same torque values as standard valves shown on pages 4, 5 and 6. Series 94 valves with UHMWPE, High-per Fill and Metal G seats use grafoil stem seals which have higher operating torques. Similarly, Series AF94 and FZ94 valves with TFE, reinforced TFE, Polyfill and Metal G seats also use grafoil stem seals. These higher torque curves are shown on pages 7 and 8; two are not shown, UHMWPE and High-per Fill. To obtain torques for these two seats, use torque values from the High-per Fill curves on pages 4 and 5 and the UHMWPE curves from page 6 with the following adders:

¼" – ¾"	90 in-lb	3" – 4"	200 in-lb
1" – 1¼"	120 in-lb	6"	350 in-lb
1½" – 2"	150 in-lb		

Actuator Selection

Once the torque requirements of the valve have been determined, the actuator can be properly sized.

Pneumatic Actuators

Before sizing the actuator for the valve, there are a few pieces of information which must be determined including the style of actuator (Series 34 or 39), the minimum air supply pressure available, and the type of operation (double-acting or spring-return) that the actuator is to perform. If the actuator is to be spring-return, the failure mode (fail closed or fail open) must also be determined.

1. Double-Acting Operation — Select the actuator whose torque output, at the minimum air supply pressure, exceeds the calculated torque requirements of the valve. Actuator torque output charts are shown on pages 12 and 13.
2. Spring-Return Operation, Fail Closed — Select the actuator whose torque output, at the minimum air supply pressure, at the end of spring stroke exceeds the torque required to close the valve.
3. Spring-Return Operation, Fail Open — Select the actuator whose torque output, at the minimum air supply pressure, at the end of air stroke exceeds the torque required to close the valve.

Electric Actuators

There are a few terms associated with electric actuators that require definition. Actuator startup torque is the amount of torque initially produced by an actuator when starting from rest. Use startup torque when selecting an electric actuator for a ball valve. Actuator stall torque is the amount of torque produced by the actuator just prior to the point where the motor stalls.

Select the actuator whose startup torque output exceeds the breakaway torque requirements of the valve. Electric actuator torque outputs are shown on page 12.

For valves other than ball valves, actuators must be selected such that startup torque exceeds the maximum torque rating of the valve.

Before making a final selection, make sure that the electric actuator selected is available in the required voltage. Not all electric actuators are available in all voltages.

Pressure Torque Curves

Standard Reduced Port Valves and Series 94 Valves with TFE Stem Seals

TFE Seats

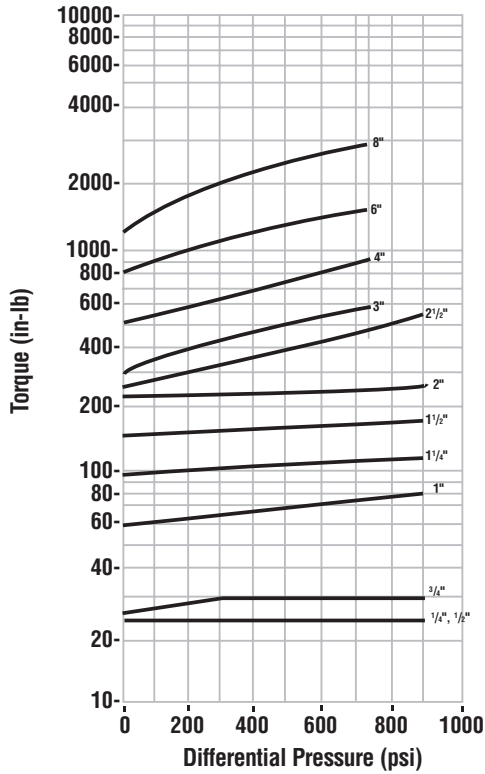

Polyfill Seats

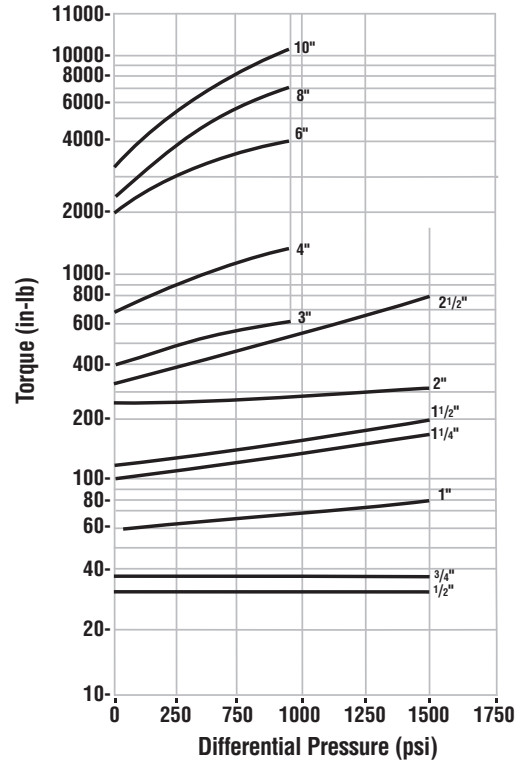

Reinforced TFE Seats

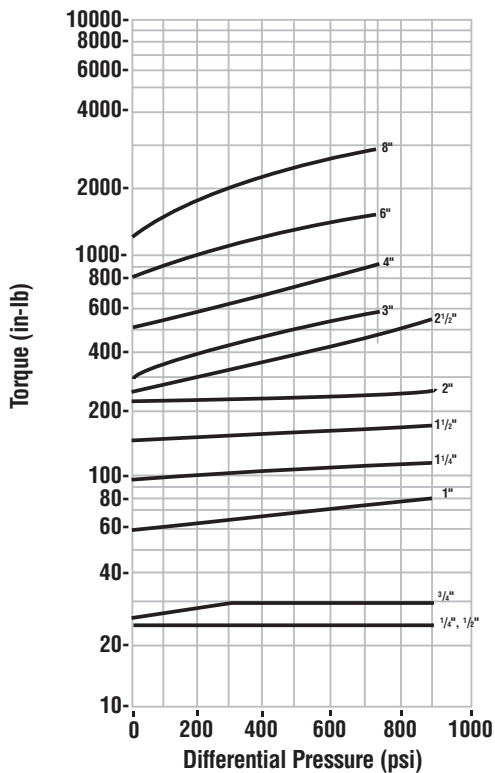

High-per Fill Seats*

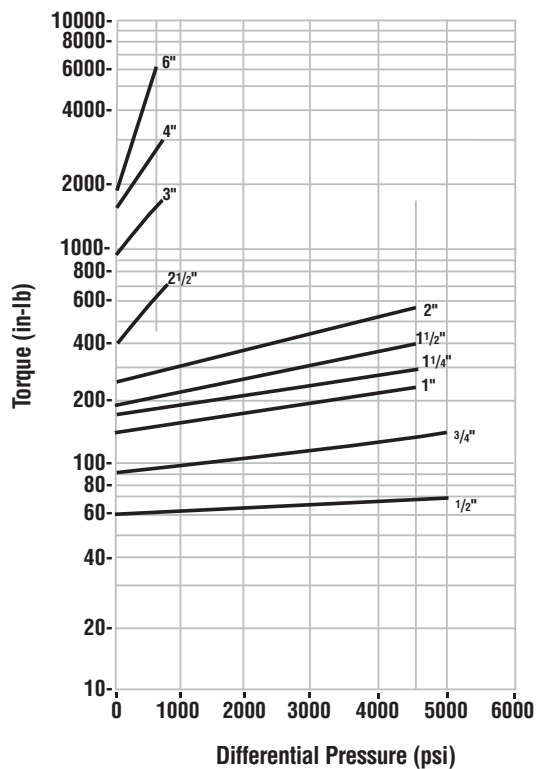

Pressure Torque Curves

Standard Reduced Port Valves and Series 94 Valves with TFE Stem Seals

Use Torque Curves on this page for 3" – 8" valve models older than:

44, 151/301: R13; 45, 59: R3; 94: R2; 51/52: R6; 818/828: R4; 82/83: R2

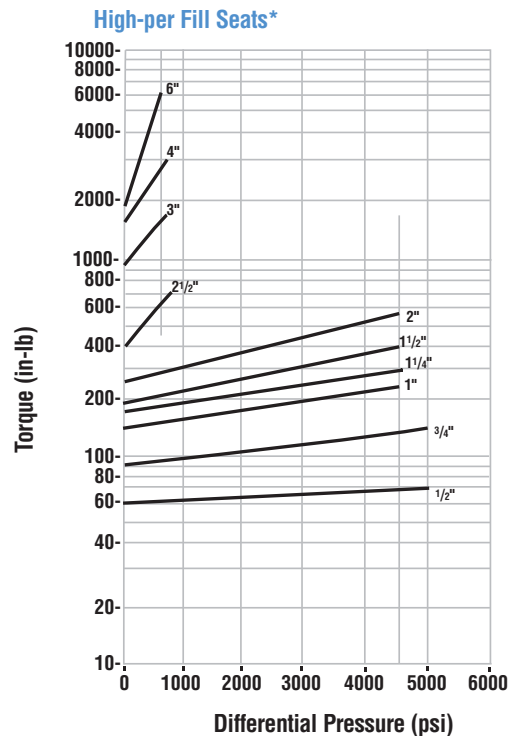
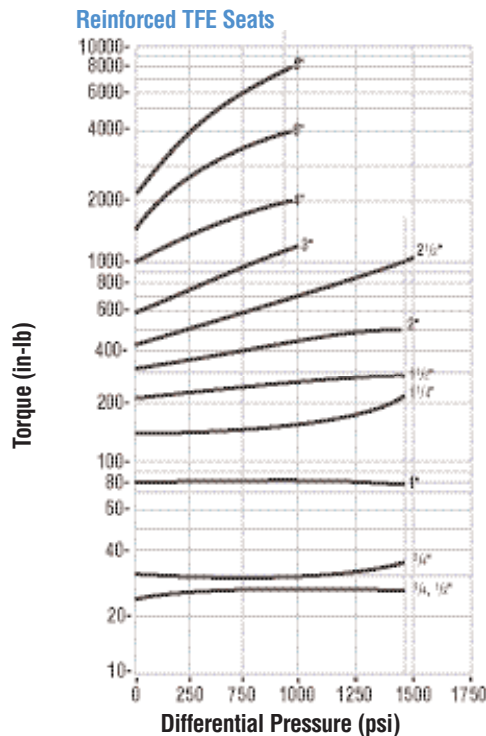
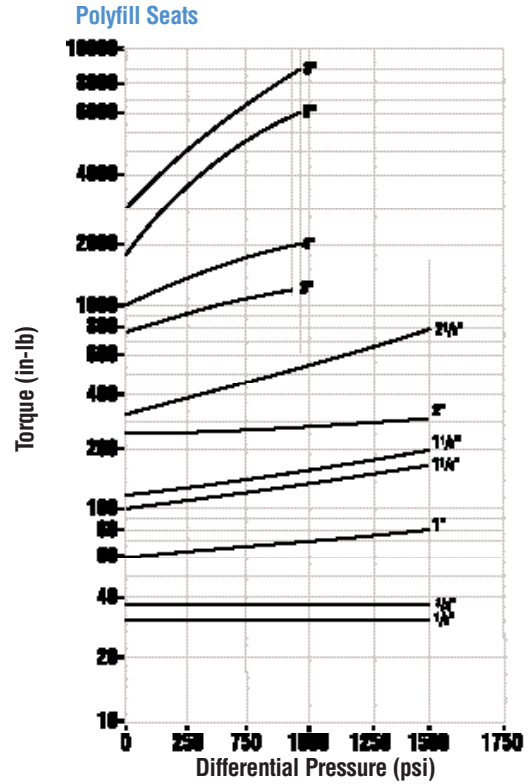
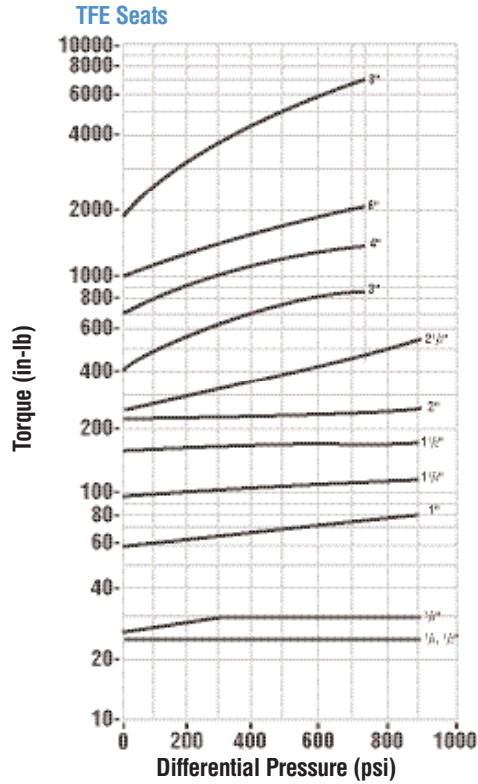

Note: 8" and 10" Reinforced TFE Seat Torques for full port valves on Page 10.

*If used in Series 94 valve with Grafoil stem seals, see "Series 94 Valves" paragraph on page 3.

Pressure Torque Curves

Standard Reduced Port Valves and Series 94 Valves with TFE Stem Seals

UHMWPE Seats*

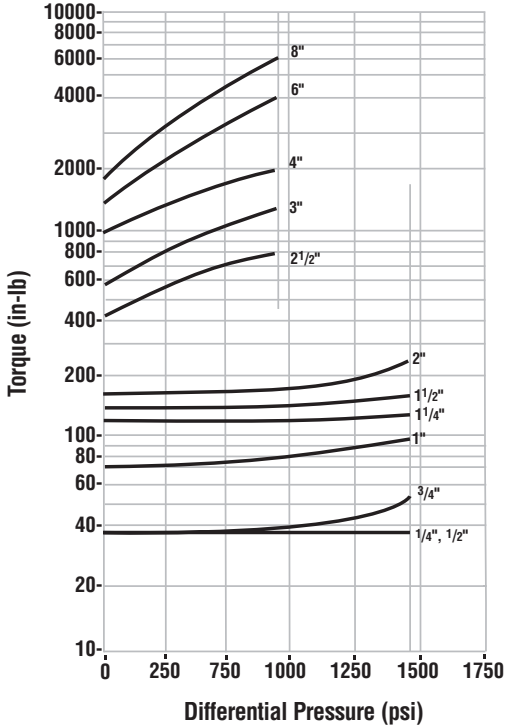

Lubetal Seats

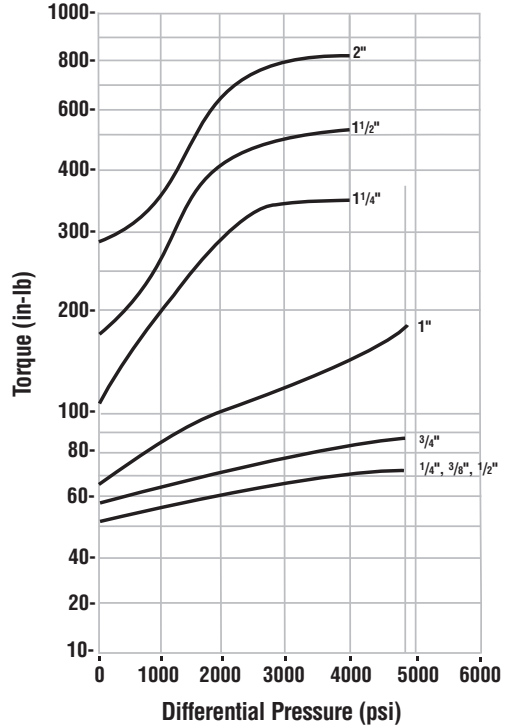

*If used in Series 94 valve with Grafoil stem seals, see "Series 94 Valves" paragraph on page 3.

Metal "A" and Metal "G" Seats

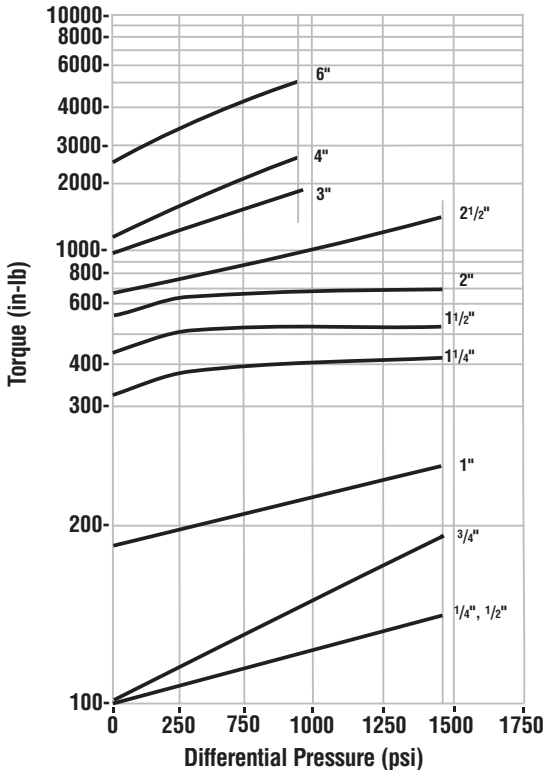

**High-per Fill Seats
1/2" - 2" Series H71 High-Pressure Valves**

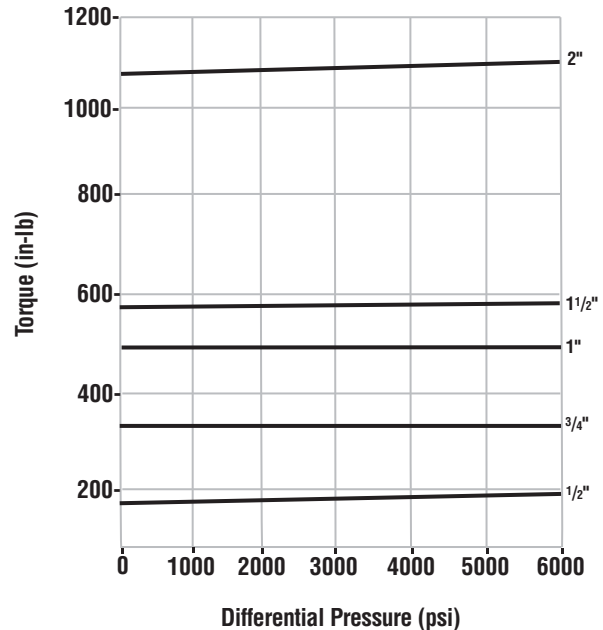

Pressure Torque Curves

Series 94, AF94 and FZ94 Valves with Grafoil® Stem Seals*

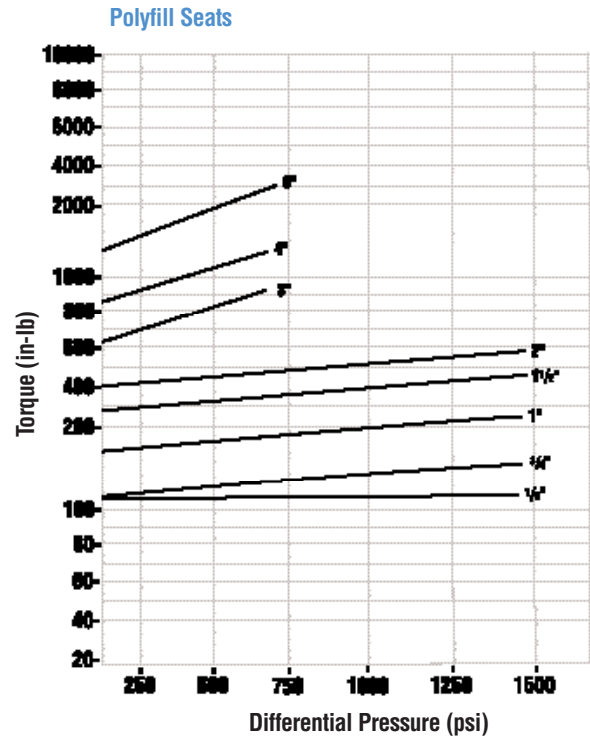
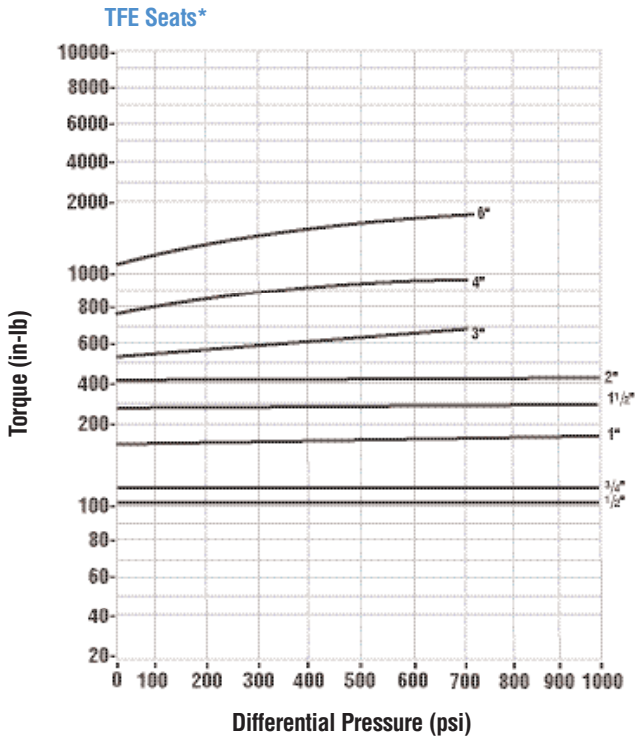

* Use curves on pages 4 and 5 for Series 94 valve with TFE stem seals. If using "High-per Fill" or UHMWPE seats with the above valves (with Grafoil stem seals), use torque values from High-per Fill curves on page 4 or UHMWPE curves on page 5 with the following adders: 1/2" - 3/4", 90 in-lb; 1", 120 in-lb; 1 1/2" - 2", 150 in-lb; 3" - 4", 200 in-lb; 6", 350 in-lb.

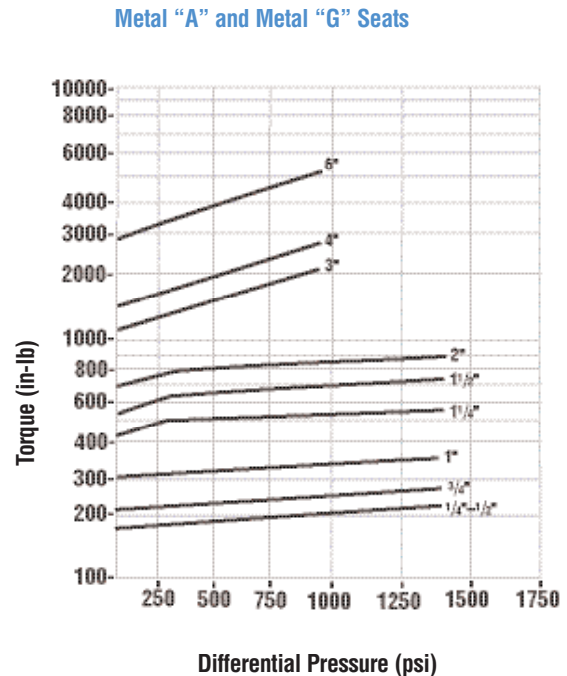
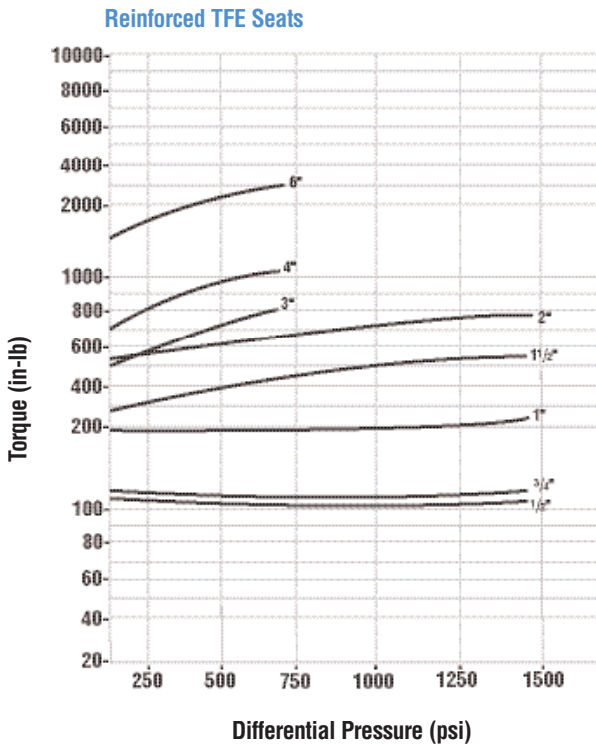

Pressure Torque Curves

Series 94, AF94 and FZ94 Valve with Grafoil® Stem Seals*
Use Torque Curves on this page for Revision R1 Valves

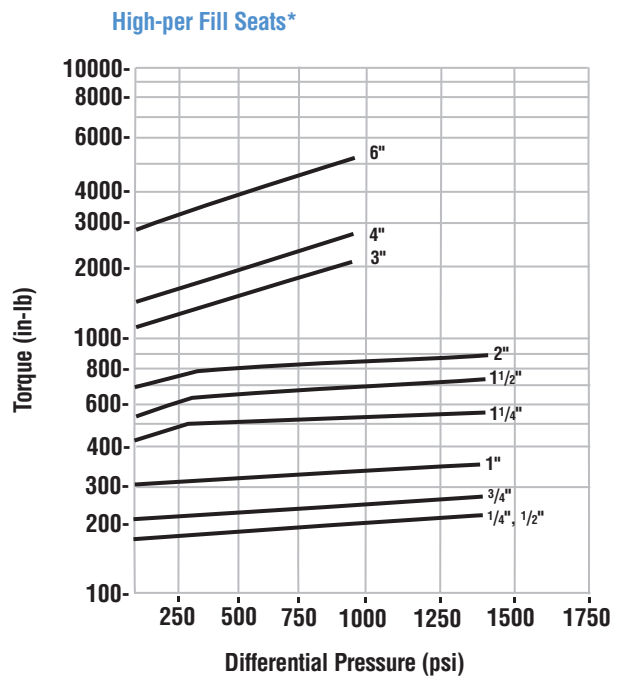
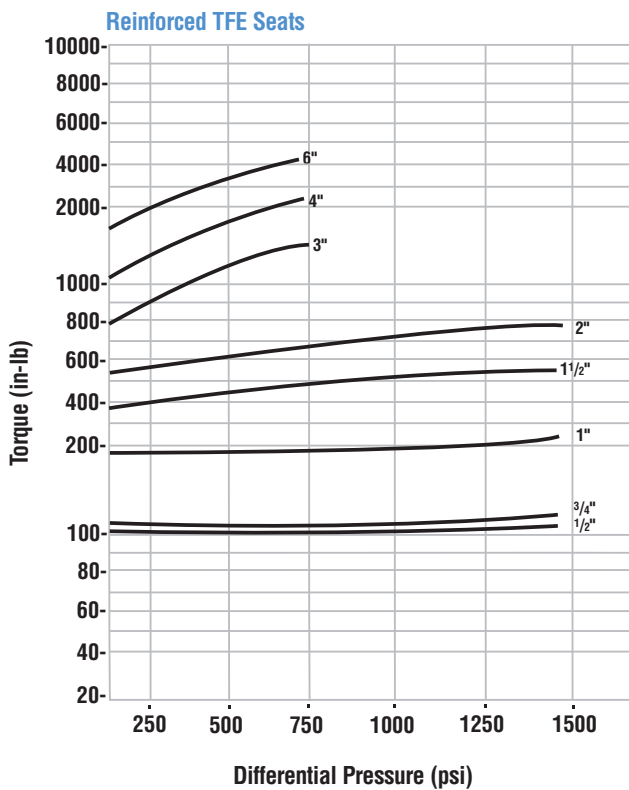
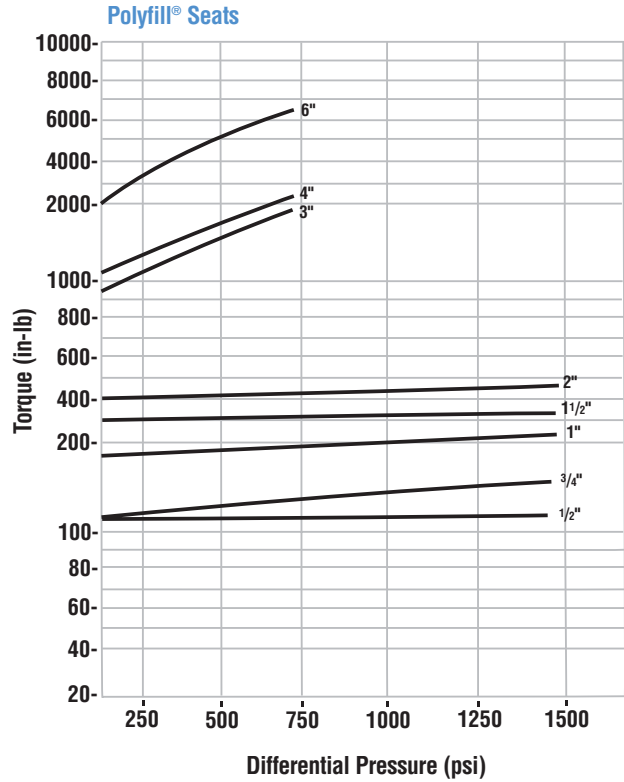
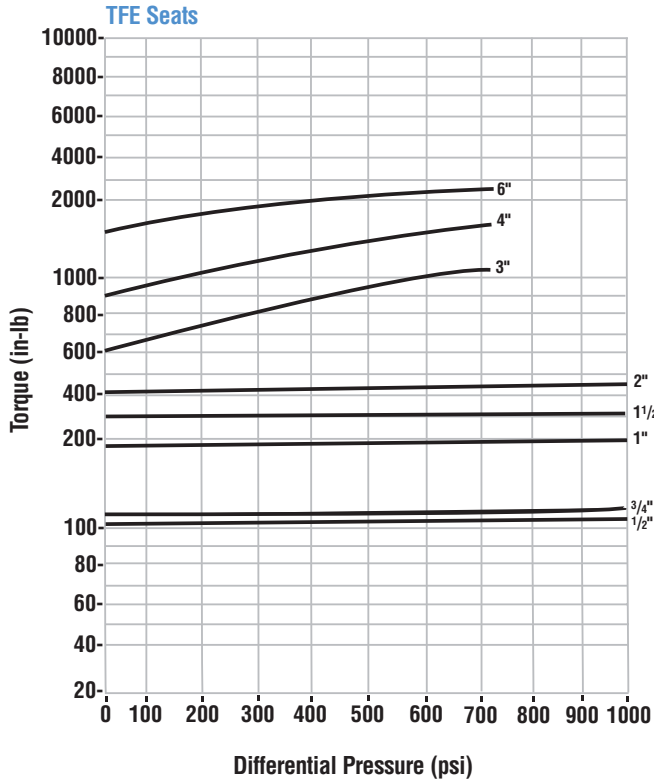

* Use curves on pages 4 and 5 for Series 94 valve with TFE stem seals. If using High-per Fill or UHMWPE seats with the above valves (with Grafoil stem seals), use torque values from High-per Fill curves on page 4 or UHMWPE curves on page 5 with the following adds: 1/4" - 3/4", 90 in-lb; 1", 120 in-lb; 1 1/2" - 2", 150 in-lb; 3" - 4", 200 in-lb; 6", 350 in-lb.

Pressure Torque Curves

Polyfill Seats - Cryogenic Service Only
1/2" - 2" C4 and C4 Diverter Valves

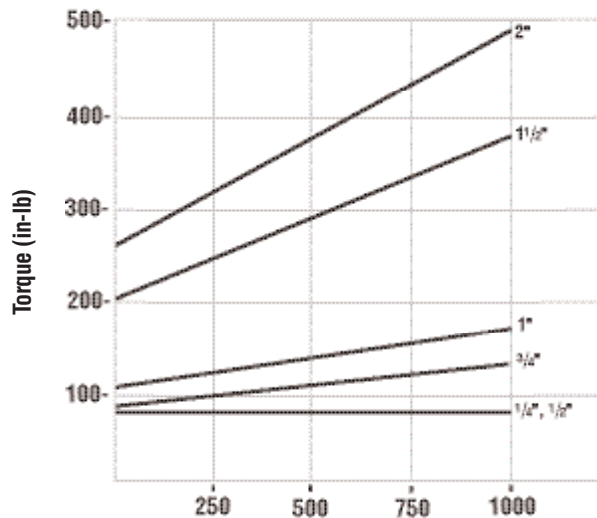

1/2" - 2" Series WK44 Valves
1/2" - 2" Series T44 Three-Way Valves
One-Piece TFE Seats

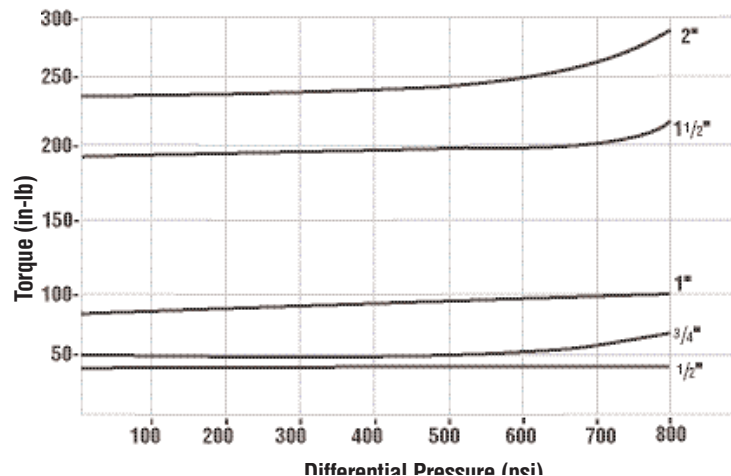

Polyfill Seats - Cryogenic Service Only
3" - 6" C4 Wafer and C51 Flanged Valves

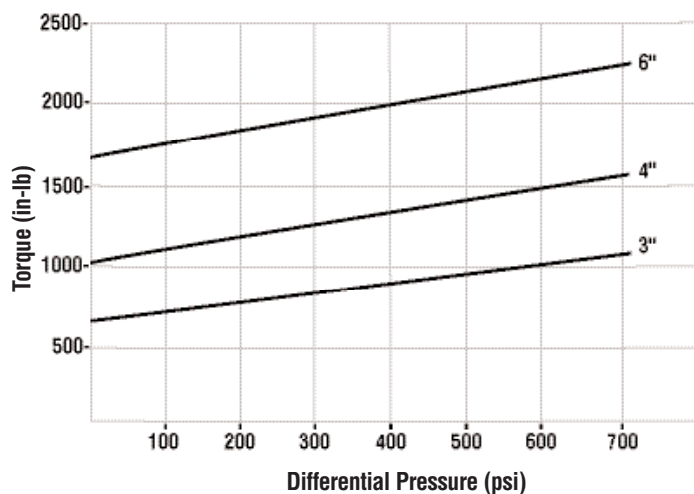

1/2" - 2" Series WK44 Valves
1/2" - 2" Series T44 Three-Way Valves
One-Piece Polyfill Seats

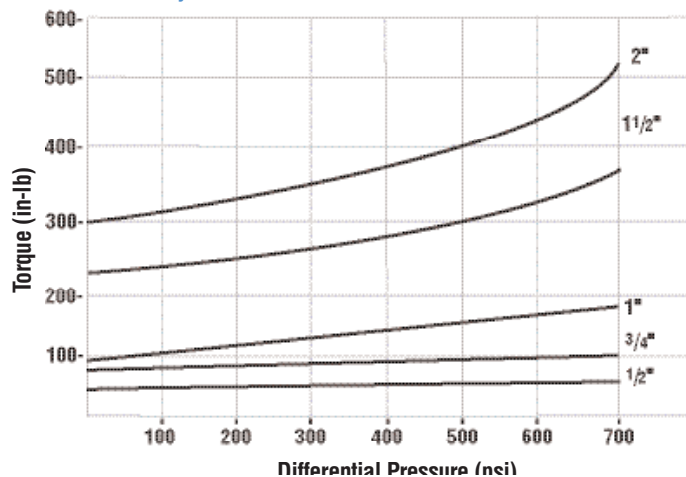

1/2" - 2" Series WK44 Valves
1/2" - 2" Series T44 Three-Way Valves
One-Piece UHMWPE

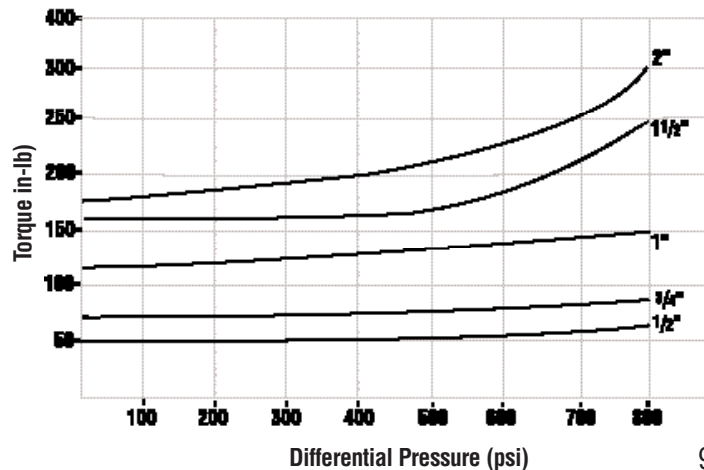

Chlorine Ball Valves with TFE or Reinforced TFE Seats	
Valve Size	Maximum Expected Breakaway Torque at Rated Pressure (in-lb)
1/2"	50
3/4"	75
1"	125
1 1/2"	450
2"	600
3"	1200
4"	2000

Pressure Torque Curves

TFE Seats
10" Standard Reduced Port Valve

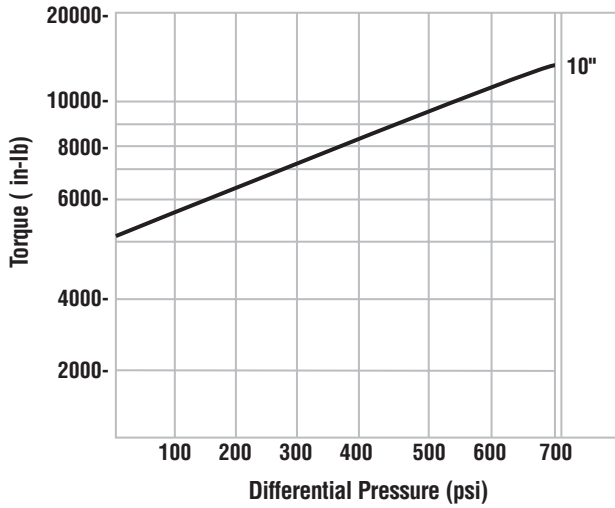

Reinforced TFE Seats
8" and 10" Series 82/83 Full Port Valves
8" Series 818/828 Full Port Valves

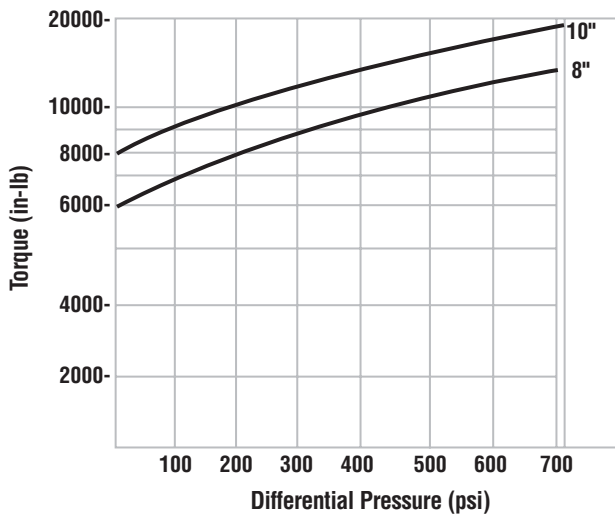

TFE Seats
1/2" - 2" Series WK70 Clean Valves

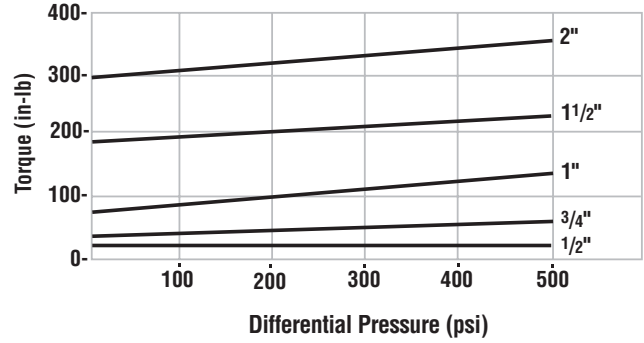

Reinforced TFE Seats
1/2" - 2" Series WK70 Clean Valves

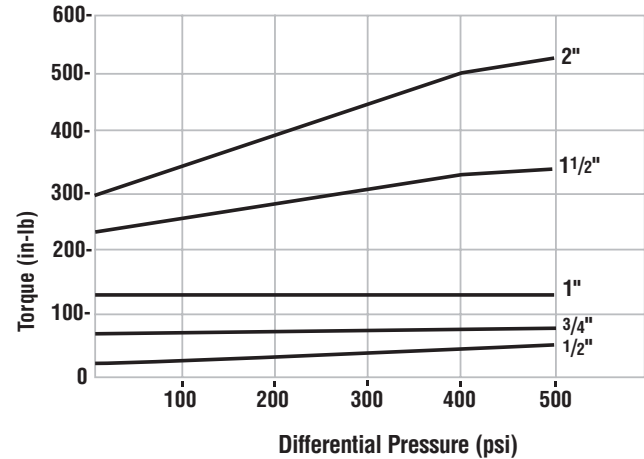

Polyfill Seats
1/2" - 2" Series WK70 Clean Valves

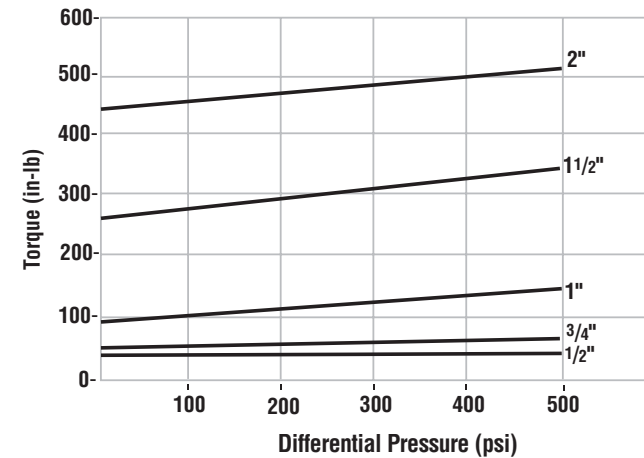

Pressure Torque Curves for CPT Control Valves

Metal "A" and Metal "G" Characterized Seats with Metal "A" (A), Metal "G" (G), High-per Fill (X), fluoropolymer (T) or Polyfill (P) Round Seats†

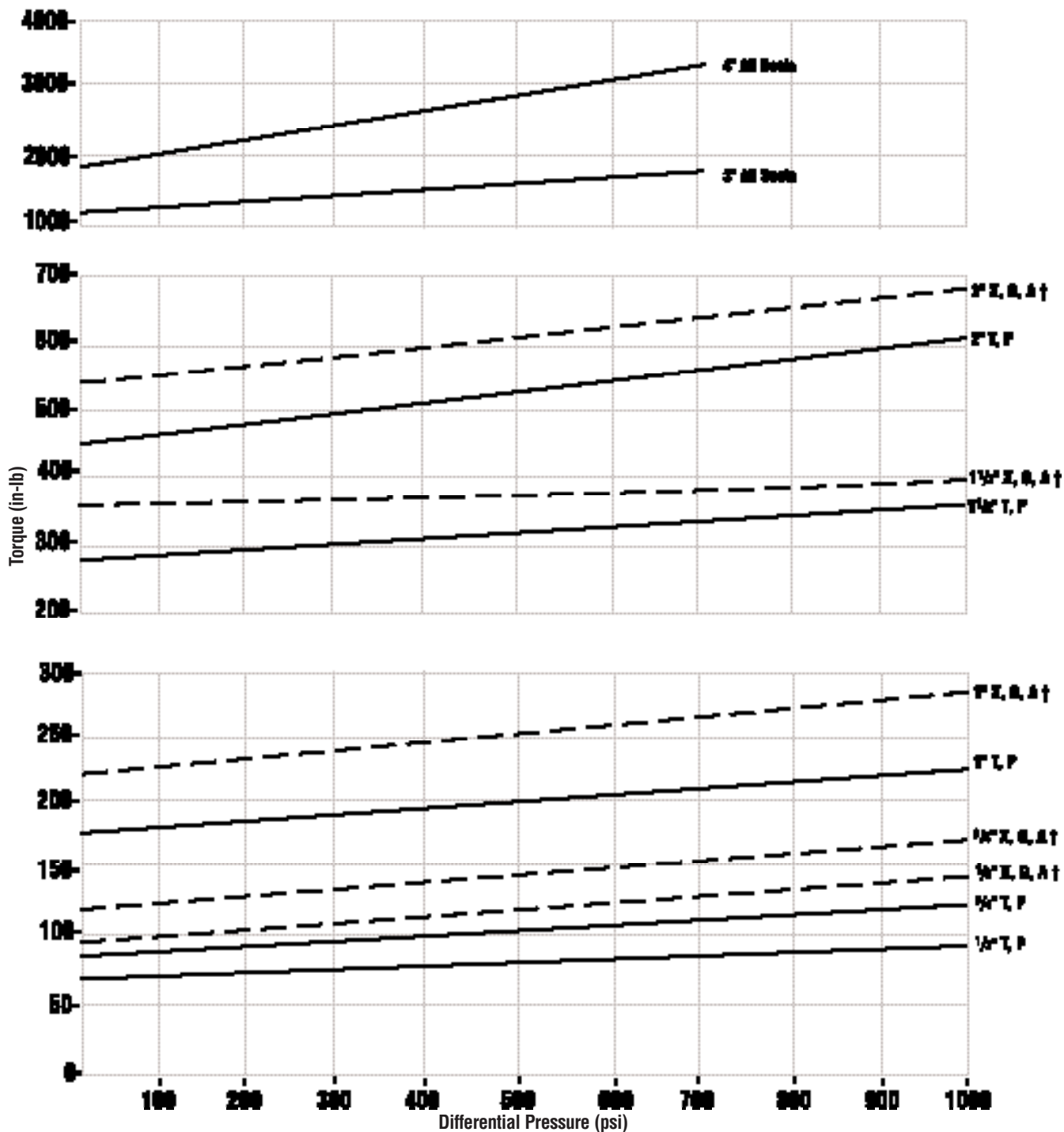

† For Series CPT94 control valves with grafoil stem seals, add the following torque values to the curve values above: 1/2" - 3/4", 90 in-lb; 1 1/2" - 2", 150 in-lb; 3" - 4", 200 in-lb.

Actuator Output Charts (in-lb)

Series 34 - Double-Acting

Actuator Size	OPERATING PRESSURE		
	60 psi	80 psi	100 psi
A	120	160	200
B	600	800	1000

Series 36 - Electric

Actuator Size	Startup Torque
10	120
20	480

Series 34 - Spring-Return

Actuator Size	Stroke	OPERATING PRESSURE	
		Start	End
A	Air Spring	140	75
		140	75
B	Air Spring	800	170
		800	200

Series 75 - Electric

Actuator Size	Startup Torque
10	120
12	180
15	260
20	480
22	720
23	950
25	1440
30	2400

Series 39 - Double-Acting

Actuator Size	OPERATING PRESSURE									
	30 psi	40 psi	50 psi	60 psi	70 psi	80 psi	90 psi	100 psi	110 psi	120 psi
05	33.6	48.6	59.7	73.5	86.3	97.4	106	126	137	148
10	80	125	160	200	245	270	310	350	385	425
15	155	240	300	370	460	510	580	650	725	790
20	285	435	545	680	840	935	1070	1200	1330	1460
25	590	785	980	1180	1375	1570	1770	1965	2160	2355
30	790	1200	1500	1860	2305	2580	2935	3290	3645	4000
33	1600	2230	2280	3520	4160	4800	5430	6070	6720	7330
35	2220	2975	3900	4800	5600	6400	7200	8000	8800	9600
40 Rev. 3	3510	4710	6170	7390	8710	10040	11400	12700	13970	15270
42 Rev. 3	6500	8700	10900	13090	15330	17530	19720	21920	24120	26310
45 Rev. 1	9000	12700	16100	19500	22700	26000	29400	32600	36000	39500
50 Rev. 1	13145	19000	24000	29000	34000	40000	45000	50000	55000	60000

Actuator Output Charts (in-lb)

Series 39 - Spring-Return

Size	Stroke	Operating Pressure											
		30 psi		40 psi		50 psi		60 psi		70 psi		80 psi	
No. of Springs		Start	End	Start	End	Start	End	Start	End	Start	End	Start	End
						2		2		2		4	
0539	Air Spring					28	15	35	30	50	40	45	30
						41	31	41	31	41	31	53	40
No. of Springs		2		4		6		8		8		10	
1039	Air Spring	70	40	85	60	105	60	125	70	170	120	175	95
		58	35	60	35	95	55	125	75	125	75	160	95
1539	Air Spring	140	80	130	85	200	125	240	150	280	155	325	190
		100	60	105	74	165	105	220	145	220	145	280	185
2039	Air Spring	220	150	300	240	340	235	415	280	575	440	600	360
		140	95	190	125	300	195	400	265	400	265	505	335
2539	Air Spring	220	110	560	400	600	350	730	420	925	655	980	650
		240	170	345	210	540	330	720	450	720	450	915	675
3039	Air Spring	324	180	840	610	965	600	1130	690	1675	1145	1650	920
		466	264	560	340	870	535	1160	730	1160	730	1470	920
3339	Air Spring			1550	1160	1810	1200	2060	1220	2700	1860	2950	1900
				1070	680	1680	1070	2300	1460	2300	1460	2900	1850
3539	Air Spring	1560	1260	2100	1470	2380	1450	2850	1730	3670	2615	3850	2210
		900	720	1330	950	2070	1330	2770	1815	2770	1815	3600	2300
4039	Air Spring			3410	2300	3980	2350	4470	2390	5620	3450	6150	3500
Rev.3				2420	1500	3730	2240	4870	2980	4870	2980	6210	3740
4239	Air Spring			6550	4520	7280	4140	7900	3390	10510	6190	10920	5590
Rev.3				4560	2390	6900	3800	9290	4870	9290	4890	11720	6370
No. of Springs				12		16		18		22		24	
4539	Air Spring			8700	4000	10600	4300	13200	5900	14900	6100	17600	8000
Rev.1				8300	4000	11800	6500	15800	6300	16800	7800	18000	8400
5039	Air Spring			12500	6000	15500	6000	19500	8500	21800	8000	26500	11500
Rev.1				13000	6500	18000	8500	20500	9500	26000	12200		13500

Examples:

1. Application

The customer wishes to automate a 1½" W2 4446 PMSW valve handling oil at 50 psi and 80° F. He would like a double-acting Series 39 pneumatic actuator for on-off service. The available air supply pressure for the actuator is 80 psi minimum.

Sizing Procedure

1. Determine differential pressure which the actuator is to work against (valve in closed position):

$$\begin{aligned} \text{Known pressure conditions: } P1 \text{ max.} &= 50 \text{ psig} & \text{Differential pressure: } &= P1 \text{ max.} - P2 \text{ min.} \\ P2 \text{ min.} &= 0 \text{ psig} & &= 50 - 0 \\ & & &= 50 \text{ psi} \end{aligned}$$

2. Determine valve torque at differential pressure:

From page 4 (pressure-torque curves for valves using Polyfill seats), we find that the torque required to open this 1½" valve against 50 psi differential pressure is approximately 130 in-lb.

3. Select double-acting Series 39 actuator from page 10 whose torque output at 80 psig supply pressure meets or exceeds the valve torque requirements. From this, we find that a size 1039 actuator produces 270 in-lb of torque at an 80 psig supply pressure. Since 270 in-lb exceeds 130 in-lb, the proper actuator is the size 1039.

2. Application

The customer wishes to automate a 4" 5146 T 150 valve. The valve is located in a pump house and is passing raw water from a river to be used to cool a piece of equipment. The water inlet pressure to the valve is 150 psig. The actuator is to be spring-return, fail closed and can be supplied with a minimum 50 psig air pressure.

1. Determine differential pressure (worst case) that the actuator is to work against:

$$\begin{aligned} \text{Differential pressure} &= P1 \text{ max.} - P2 \text{ min} \\ &= 150 \text{ psi.} \end{aligned}$$

2. Determine valve torque at differential pressure.

From page 4 (pressure-torque curves for valves using TFE seats), we find that the torque required to open a 4" valve against a 150 psi differential pressure is approximately 590 in-lb (for clean media). Since this is a fail closed application, we need to determine the closing torque, which is 80% of the opening torque.

$$\begin{aligned} \text{Closing torque: } &= \text{Opening torque} \times .8 & \text{Total Opening Torque: } &= \text{Opening torque} \times \text{media} \\ &= 590 \times .8 & &= 590 \times 1.8 = 1062 \text{ in-lb} \\ &= 472 & & \end{aligned}$$

Media: Raw Water factor = 1.8

Multiply the basic torque requirement by the appropriate application factor multiplier (from table on page 3).

$$\text{Valve torque (closing)} = 472 \times 1.8 = 850 \text{ in-lb}$$

3. Select spring-return Series 39 actuator (the Series 39 is the only series of pneumatic actuators made in sizes large enough to operate a 4" ball valve), whose torque output at the end of spring stroke (for fail closed operation) at a 50 psig supply pressure exceeds the amount of torque required to close the valve (reseating torque from step 2).

From Page 11, we find that a 33 39S actuator produces 1070 in-lb of torque at the end of spring stroke at 50 psig supply pressure. This actuator also produces 1810 in-lb of torque at the start of air stroke (which opens the valve) at 50 psig supply pressure. Since 1810 in-lb exceeds the 1062 in-lb required to open the valve, and 1070 in-lb exceeds the 850 in-lb required to close the valve, the 33 39S actuator is the proper size for the application.

3. Application

The customer wishes to electrically automate a 3" 5966 TSW valve handling a dilute acetic acid at 50 psig and ambient temperature.

Sizing Procedure

1. Determine differential pressure (worst case) that the actuator will work against.

The customer has only given the upstream pressure, 50 psig. Since you know no more about the application than what was stated above, the worst case situation would be when the downstream pressure (when the valve is closed) is zero. Therefore, the differential pressure that the actuator would be required to work against would be 50 psi.

2. Determine valve torque at differential pressure; since the valve in this application is a full-ported ball valve with TFE seats, determine the torque from page 4 for a valve that is one size larger than the full-ported valve, i.e., determine the torque of a 4" valve from this graph.

From page 4, we find that the torque required to open a 3" 59 series valve against a 50 psi differential pressure is approx. 550 in-lb.

3. Select the Series 75 electric actuator whose startup torque output is the same or exceeds the amount of torque required to open the 3" full-ported ball valve.

From page 10, we find that a size 2275 actuator produces a torque of 720 in-lb. Since 720 in-lb exceeds 550 in-lb, the correct actuator size is the 2275.



Worcester ... All The Right Valves In All The Right Places

Flowserve Corporation has established industry leadership in the design and manufacture of its products. When properly selected, this Flowserve product is designed to perform its intended function safely during its useful life. However, the purchaser or user of Flowserve products should be aware that Flowserve products might be used in numerous applications under a wide variety of industrial service conditions. Although Flowserve can (and often does) provide general guidelines, it cannot provide specific data and warnings for all possible applications. The purchaser/user must therefore assume the ultimate responsibility for the proper sizing and selection, installation, operation, and maintenance of Flowserve products. The purchaser/user should read and understand the Installation Operation Maintenance (IOM) instructions included with the product, and train its employees and contractors in the safe use of Flowserve products in connection with the specific application.

While the information and specifications contained in this literature are believed to be accurate, they are supplied for informative purposes only and should not be considered certified or as a guarantee of satisfactory results by reliance thereon. Nothing contained herein is to be construed as a warranty or guarantee, express or implied, regarding any matter with respect to this product. Because Flowserve is continually improving and upgrading its product design, the specifications, dimensions and information contained herein are subject to change without notice. Should any question arise concerning these provisions, the purchaser/user should contact Flowserve Corporation at any one of its worldwide operations or offices.

For more information about Flowserve Corporation, contact www.flowserve.com or call USA 1-800-225-6989.

FLOWSERVE CORPORATION
FLOW CONTROL DIVISION
1978 Foreman Drive
Cookeville, Tennessee 38501 USA
Phone: 931 432 4021
Facsimile: 931 432 5518